

SUR-RON LIGHT BEE SERVICE MANUAL



1. Brief Introduction

1.1 Safety warning

Do reading the chapter carefully before the repair & maintenance

This service manual is used to guide professional technicians. Please don't do the repair and maintenance with the content in this manual neither you take necessary training nor have any operation experience.

The operations in the manual only can be done in suitable maintenance workshop. Ensure all essential tools are well prepared before the repair and maintenance.

The power source of LIGHT BEE must be cut off before any operation on the bike. **The failure to cut off its power source may cause serious injury and even death through electric shock or disassembly and assembly of parts.**

When you do the repair and maintenance, please do wear the required cloth and shoes in case of burning, cutting, collision or other accidents. And use protective goggle or gloves if necessary.

Chongqing Qiulong Technology Co., Ltd (Hereafter called Sur-Ron) has the power of interpretation for all information in the manual. Sur-Ron aimed to build the best electric bike in the world, therefore, any improvements, which can make the bike have better performance and quality, Sur-Ron will keep doing improvements. If any content missed in this manual, or finally the bike you got is a little different from the description of this manual, please check with the local importer or dealer before you do the repair and maintenance.

1. Brief Introduction
 - 1.1 Safety warning
 - 1.2 Use of the manual
 - 1.3 Disclaimer
2. Technical specification
 - 2.1 Bike parameters
 - 2.2 Torque specifications of important screws
 - 2.3 The top speeds under different battery capacities
 - 2.4 Bike composition
3. Bike operation
4. LIGHT BEE repair tools and preparation work
 - 4.1 LIGHT BEE repair tools
 - 4.2 LIGHT BEE fixing
5. Battery dismount and mount
6. Absorber dismount, mount, and adjustment
 - 6.1 Adjust the compression damping of front absorber
 - 6.2 Adjust setting of absorber
 - 6.3 Absorber lubricating
 - 6.4 Front absorber dismount and mount
 - 6.5 Rear absorber dismount and mount
 - 6.6 Disassembly of rear absorber
7. Check, dismount, mount of the headset
 - 7.1 Check stroke gap of headset
 - 7.2 Disassemble the headset
8. Disassemble and assemble handle bar assembly
9. Wheel checking
 - 9.1 Tire checking
 - 9.2 Rim checking
10. Braking system checking and maintenance
 - 10.1 Brake checking
 - 10.2 Maintenance
 - 10.3 Brake lever dismount and mount
 - 10.4 Brake pump dismount and mount
 - 10.5 Brake clipper dismount and mount
 - 10.6 Brake clipper adopter dismount and mount
 - 10.7 Front brake assembly dismount and mount
 - 10.8 Rear brake assembly dismount and mount
11. Bike body dissemble and assemble
 - 11.1 Mid. Bushing dismounting and mounting
 - 11.2 Motor side-cover dismounting and mounting
 - 11.3 Motor side-cover dismounting
 - 11.4 Disassemble and assemble first level transmission belt
 - 11.5 Disassemble and assemble left pedal assembly

- 11.6 Disassemble left pedal assembly
- 11.7 Disassemble and assemble right pedal assembly
- 11.8 Disassemble pedal assembly
- 11.9 Disassemble and assemble guard plate under electrical machine
- 11.10 Disassemble and assemble guard plate under controller
- 11.11 Disassemble and assemble air switch combination
- 11.12 Disassemble air switch combination
- 11.13 Disassemble and assemble USB and electric control lock combination
- 11.14 Disassemble USB and electric control lock
- 11.15 Disassemble and assemble electrical machine assembly
- 11.16 Disassemble and assemble tailstock assembly
- 11.17 Disassemble tailstock assembly
- 11.18 Disassemble and assemble left and right limited block of battery
- 11.19 Disassemble and assemble horn
- 11.20 Disassemble and assemble back shield
- 11.21 Disassemble and assemble rear wheel assembly
- 11.22 Disassemble rear wheel
- 11.23 Disassemble and assemble rear fork
- 11.24 Disassemble rear fork
- 11.25 Disassemble rear fender assembly
- 11.26 Disassemble rear and inner fender
- 11.27 Disassemble and assemble cover of battery compartment
- 11.28 Disassemble and assemble lower stop plate of battery
- 11.29 Disassemble lower stop plate of battery
- 12. Checking and maintenance of speed regulation control and brake control device
 - 12.1 Check brake
 - 12.2 Check accelerator
 - 12.3 Confirm power supply control
- 13. Position adjustment
 - 13.1 Adjust handlebar
 - 13.2 Adjust brake handle
- 14. Disassembly
 - 14.1 Dismount handlebar of accelerator
 - 14.2 Dismount handlebar
 - 14.3 Dismount throttle bracket
- 15. Transmission gear
 - 15.1 Check chain and chain wheel
 - 15.2 Clean and lubricate chain
 - 15.3 Disassemble and assemble chain
- 16. Electric system
 - 16.1 Electric system drawing
 - 16.1 Check electric system
- 17. The use and maintenance of battery
 - 17.1 Disassembly and assembly of battery

- 17.2 Maintenance and storage of battery
- 17.3 Battery charging
- 18. Checking and maintenance of controller
 - 18.1 Disassembly and assembly of controller
 - 18.2 Checking of controller
- 19. Electrical failure checking and removal
- 20. Failure diagnosis

1.2 Use of the manual

 The symbol represents the dangers the bike may cause or other dangerous situations.

 The symbol represents the dangers which may cause serious physical injuries.

 The symbol represents the potential dangers which can cause harm to health.

1.3 Disclaimer

Modification of the bike may cause physical injuries.

The modification of the bike without approval of Chongqing Surron Technology Co., Ltd. will lead to the following results:

- Loss of warranty.
- Needs for another driver's license.
- Accidents and serious injuries.

Please read local provisions about electromobile and motor vehicle before using Qingfeng bike.

 **According to the certification of LI2-B electric moped Sur-Ron bike has passed, its highest speed is 45km/h, so it is not allowed on expressway or the road segment with the minimum speed of more than 45km/h.**

If you have any question, please contact any official dealer of Chongqing Surron Technology Co., Ltd.

The applicable laws require you to provide the following information:

- Your age.
- The equipment necessary for special route.
- Special license for the bike.
- The area with restrictions on vehicles.

2. Technical specification

2.1 Bicycle parameters

Electromotor	
type	Brushless permanent magnet synchronous DC motor (highest power 4.0W) PMAC radial flow brushless, air-cooled and integrated rotate speed and temperature sensor.
control unit	AC/DC three-phase control unit (highest power 60V-80A) has two available driving patterns: SPORT: 2 kW ECO: 0.9 kW
highest speed	≤45 km/h
power source	
type	high-expanded ternary lithium power battery(60V32AH)
rated capacity	1900wh
charger	The special high-performance portable charger for LIGHT BEE power battery Power: 600 W Input: 110V AC or 240V DC (according to local voltage) Output: 67.2V DC/10A
charging time (standard)	0%-100% - 3.5 hours 0%-95% - 3 hours 0%-80% - 2 hours
mileage	
continuation of journey	ECO mode (average speed 25km/h)>100km
electromotor	double-stage reduction drive system
bicycle frame/hanger	bracket/brake
bicycle frame	Double-beam cradle type,

rear shock absorber	multi-link central shock-proof system
stroke of front fork	200mm.
stroke of rear wheel	210mm.
front brake	target at 4-piston hydraulic disk brake, disk 203mm
rear brake	target at 4-piston hydraulic disk brake, disk 203mm
front tire	cross-country 70/100-19
rear tire	cross-country 70/100-19
front wheel disk	Aluminum- 19*1.4
rear wheel disk	Aluminum- 19*1.4
front shock absorber	double-shoulder fully adjustable oil pressure reed inverted front shock absorber
rear shock absorber	multi-link fully adjustable damping single-tube air pressure damping system
size	

wheel base	1,230mm
height of vehicle seat	815 mm
front rake of seat tube	26°
ground clearance	270 mm
total length	1860 mm
width	780 mm
height	1,050 mm
weight	
no battery	42Kg
bicycle	50 Kg
load capacity	100 Kg

2.2 Torque specification of important screws

serial number	item	diameter of thread mm	tightening torque N.m
1、	install left support and right support under controller	M6	8N•m
2、	fasten front disk brake	M5	8~10N•m
3、	fasten rear disk brake	M6	10~12N•m
4、	fasten rear chain disk	M8	20~25N•m
5、	rear shock absorber, cocket centring	M8	20~25N•m
6、	fasten bolt of belt wheel	M6	12N•m
7、	fasten bolt of output shaft sprocket	M6	12N•m
8、	fasten nut of front belt wheel	M12	40~50N•m
9、	attachment bracket of left and right pedals and support of left and right pedals	M10	40~45N•m
10、	fasten support plate under battery	M6	8N•m
11、	fasten bolt of connecting plate	M6	10N•m
12、	fasten bolt of standing seat	M5*25	5-6N•m
13、	fasten bolts of standing seat and handlebar tube	M5	5-6N•m
14、	fasten front axle	M12	20~25N•m
15、	fasten front disk brake	M6	12N•m
16、	fasten bottom fork shaft	M10	35N•m
17、	fasten auxiliary frame and bicycle frame	M8	20N•m
18、	fasten nut of seat cushion	M6	8N•m
19、	rear shock absorber, bicycle frame and bottom fork	M8	25-30N•m

20、	fasten rear wheel and axle	M12	55~60N•m
21、	fasten rear disk brake	M6	12N•m
22、	fasten electrical machine	M8	25N•m
23、	fasten controller and support of controller	M6	8-10N•m
24、	fasten pedal and bicycle frame	M8	25-30N•m
25、	fasten guard bolt under controller	M8	20N•m

2.3 The highest speeds under different battery capacities (reference)

serial number	battery capacity	speed(km/h)
1	100%	42.8
2	90%	42.3
3	80%	41.6
4	70%	40.9
5	60%	40.1
6	50%	39.4
7	40%	38.7
8	30%	37.8

2.4 Bicycle arrangement

2.4.1 Position of bicycle parts

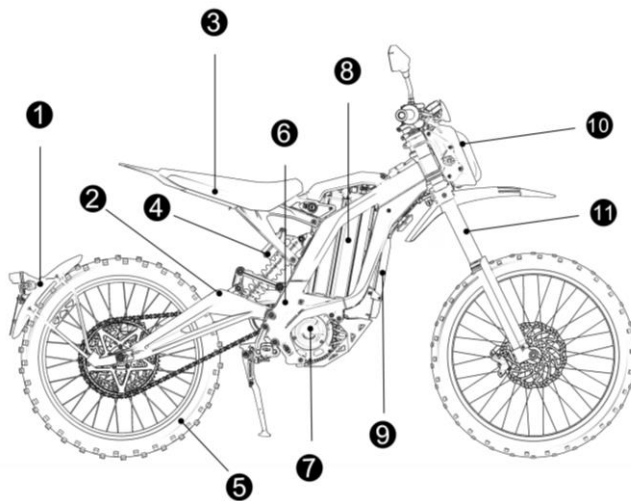

Fig 1

1. Rear fender assembly
2. Rear bottom fork
3. Seat cushion
4. Rear shock absorber
5. Tire
6. Bike frame

- 7. Three-phase brushless DC motor
 - 8. Ternary power lithium battery
 - 9. Control system
 - 10. Headlight
 - 11. Front shock absorber
- 2.3.2 Position of head parts

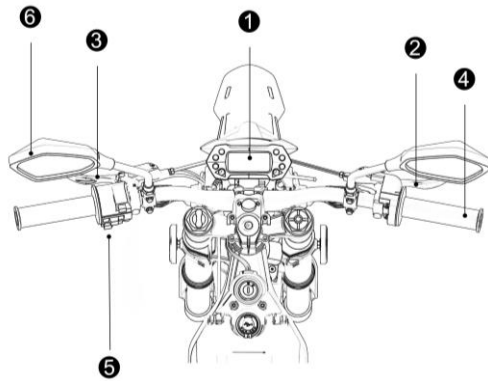

Fig 2

- 1. LCD Speedometer
- 2. Front brake handle
- 3. Rear brake handle
- 4. Throttle grip
- 5. Control switch
- 6. Rear-view mirror

2.3.3 LCD Speedometer functions

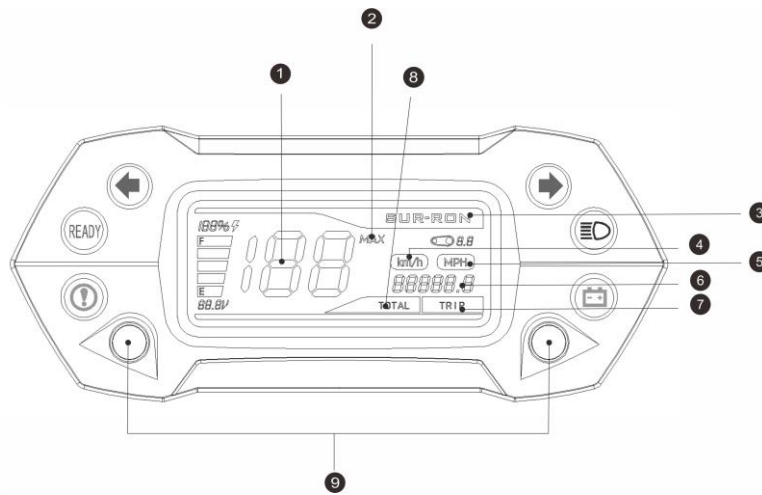

Fig 3

- 1. current speed
- 2. Top speed notice
- 3. brand logo
- 4. KMH indication
- 5. MPH indication
- 6. Mileage
- 7. Single trip distance

8. Trip distance in total
9. Buttons for function selections

3. Vehicle operation

This chapter includes all necessary knowledge related to Light Bee operation you need to learn about:



**When stop using SUR-RON light bee, cut off main switch.
Just to move the bike, turn off on/off switch.**



If you plan to use the bicycle after more than 30 days, we suggest you to take battery down, keep its capacity not less than 50% and charge it at least every month. Only the charger and cable equipped for the bicycle can be used because they are specially designed for the parts of the bicycle.



Only original charger can be used in charging

In order to achieve the best battery performance, charge the bicycle immediately after use every time.



Full discharge may damage battery



The charging and electric power storage not conforming to the instructions in the manual will invalidate the warranty of battery. These instructions are the results of strict test and can help to achieve the maximum performance and longest service life of battery.



**Cut off air switch or dismount battery in repair or maintenance of bicycle.
Hot-line work is not allowed in case of part damage or accidents**

3. Repair tools and preparation work (tools can be arranged by yourself or purchased from Chongqing SUR-RON Technology Co., Ltd.. The special brake mineral oil should be purchased from Chongqing SUR-RON Technology Co., Ltd.)

4.1 Light Bee's special repair and maintenance tool kit

- 1、 inner hexagonal spearhead: S3, S4, S5, S6, S10
- 2、 outer hexagonal spearhead: S12, S17
- 3、 Round nut four-claw sleeve: S10
- 4、 cross screw driver
- 5、 AVO meter

6、 original special brake mineral oil (LBN)

7、 lubricating grease

4.2 Fix Light Bee

In terms of some maintenance operation of Light Bee, we suggest to fix Light Bee according to the step.

In an open area, turn off power source, open Light Bee's side stand on floor.

5. Disassemble and assemble battery (see Fig 4)

5.1 After closing electric door lock, plug key into cover of ① battery compartment, then turn key anticlockwise to open cover of battery compartment

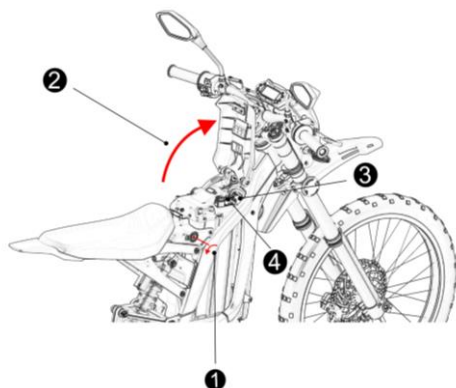

Fig 4

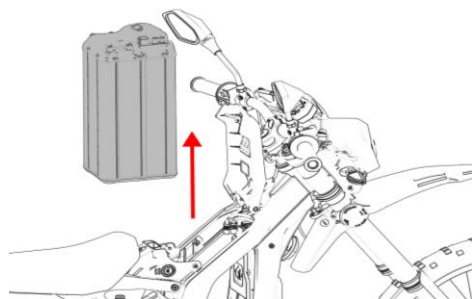

Fig 5

.Cut off air switch, power source and output power line and signal line of battery ③ ④

.Hold the lifting handle of battery, lift it, then take battery out(see Fig 5)

5.1.1 Assembly

• Assemble battery according to the inverse disassembly steps.

6. Disassemble, assemble and tune damping system

6.1 Adjust compression damping of front shock absorber (see Fig 6)

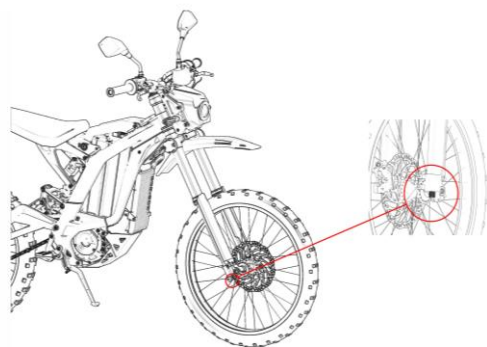

Fig 6

The compression damping of front shock absorber is adjusted through the standard valve core at the lower right. High-pressure pump is necessary. The recommended pressure is 7-10BAR(100-150 psi).

6.2 Adjust the setting of shock absorber

6.2.1 Tune front shock absorber(see Fig 7)

Adjust rebound damping (right shock absorber)

turn to +

restrain increase (slower)

turn to -

restrain decrease (faster)

preload adjustment (left shock absorber)

turn to +

increase of spring preload

turn to -

reduction of spring preload

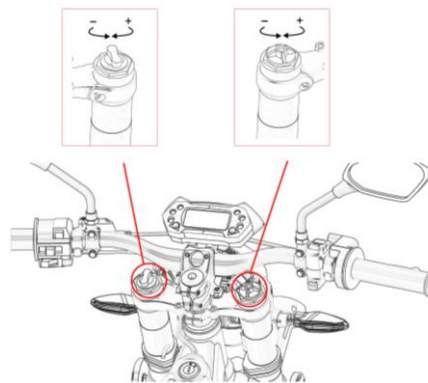

Fig 7

6.2.2 Tune rear shock absorber (see Fig 8)

regulating valve of compression damping force

turn to +, compression pressure increases(harden)

turn to -. compression pressure lowers (soften)

regulating valve of rebound damping force

turn to +, restrain increase (slower)

turn to -, restrain decrease (faster)

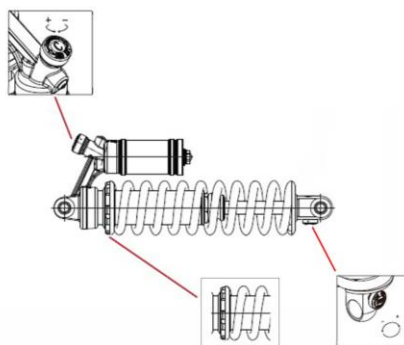

Fig 8

adjustment of spring preload

turn nut clockwise to increase preload force

turn nut anticlockwise to reduce preload force

6.3 Damping and lubrication



Warning: Light Bee's shock absorber is designed for non-detachable, don't attempt to open or disassemble shock absorber.

Don't disassemble Light Bee's shock absorber. Please lubricate hanger bracket according to the following steps and keep its best state:

- dismount protective cover. (see Fig 9)
- unscrew fixed mount of dustproof ring and slide it along pillar
- clean the dust on breeches pipe (mud and old lubricating oil)
- Smear a layer of special lubricating oil for Light Bee on the pillar between fixed mount of dustproof ring and breeches pipe.
- Tighten dustproof ring to keep lubricating oil inside it.

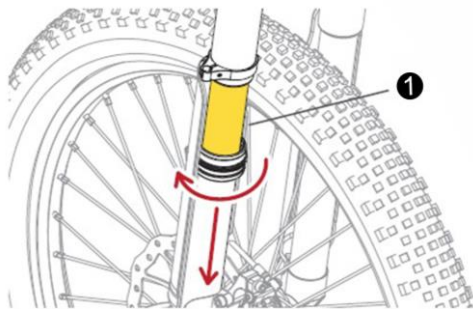

Fig 9

6.4 Disassemble and assemble front damping system

6.4.1 Disassemble front bow cap and instrument (see Fig 10)

- Dismount bolts of bow cap (1)(2) take down front bow cap and disconnect lamp line
- Dismount bolts of support of bow cap (3)(4) disconnect instrument line and take down instrument and support of bow cap.

6.4.1.1 Assembly

- Assemble front damping system according to the inverse disassembly steps and fasten it with the torque force of 10~12N.m.

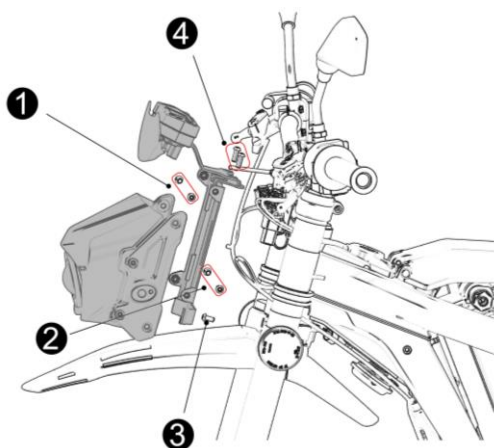

Fig 10

6.4.2 Disassemble headlight and front turn light (see Fig 11)

- .Dismount turn light, install nuts and take down turn light
- .dismount bolts of support of bow cap (2) and separate headlight and bow cap (1)(3)
- .dismount bolts of headlight and separate headlight and bow cap (1)(4)

6.4.2.1 Assembly

- Assemble headlight and turn light according to reverse disassembly steps and fasten them with the torque force of 10~12N.m.

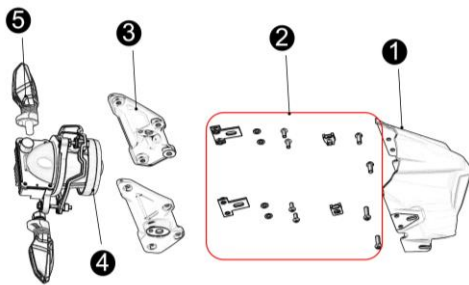

Fig 11

6.4.3 Disassemble front wheel assembly

- Loosen fastening bolts of wheel and axle of lower support of front shock absorber①
- Dismount fastening bolts of front wheel and axle, draw wheels and axles out and dismount front wheel assembly
- Dismount bolts of front fender and lining②and front fender

6.4.3.1 Assembly

- Assemble front wheel assembly according to the inverse disassembly steps, fasten front wheel and axle with the torque force of 10~12N.m and bolts with the torque fore of 20-30N.m.



Notice: it is important to fasten fastening bolts of wheel and axle alternatively and repeatedly in order to disperse loads uniformly. Fastening the second bolt may make the first bolt loose.



Ensure disk is between brake blocks in assembly of front wheel. Otherwise, brake lining or disk may be damaged.

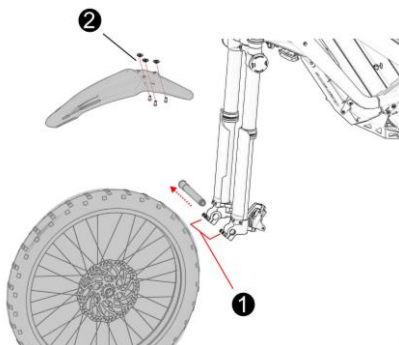

Fig 12

6.4.4.Dismount front brake disk (Fig 13, 14)

- place front wheel assembly flatwise with disk upwards. Clean and protect it.
- Dismount bolts of front brake disk①, take down front brake disk② and avoid contaminating brake disk

6.4.4.1 Assembly

- Assemble front brake disk according to the inverse disassembly steps, use thread lock

glue (Loctite 243) on bolt, fasten it with the torque force of 8-10N.m. Pay attention to rotation and install direction of brake disk, avoid contaminating brake disk, use absolute ethyl alcohol in cleaning

- Ensure disk is at a correct position (see the following figure)

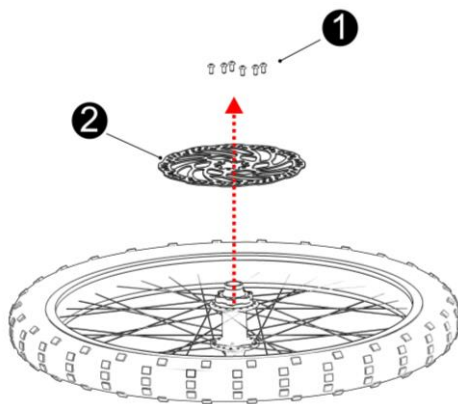

13Fig 13

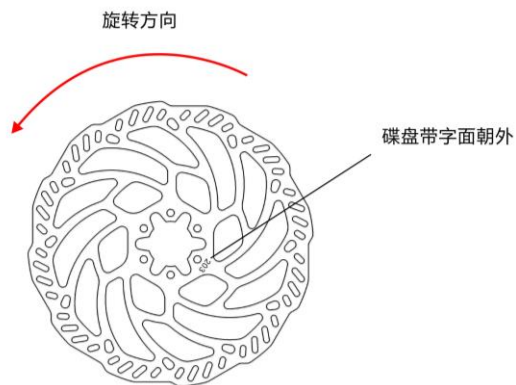

14Fig 14

6.4.5 Dismount front shock absorber (see Fig 15)

- Dismount bolts of front brake caliper and take down front brake caliper ③
- loosen fastening bolts of front shock absorber of front steering column ①, take down steering limiting gommure of shock absorber ② and take down front left and right shock absorbers

6.4.5.1 Assembly

- Assemble front shock absorber according to the inverse disassembly steps and fasten it with the torque force of 10~12N.m.



Notice: it is important to fasten bolts of shock absorber alternatively and repeatedly in order to disperse loads uniformly. Fastening the second bolt can make the first bolt loose.

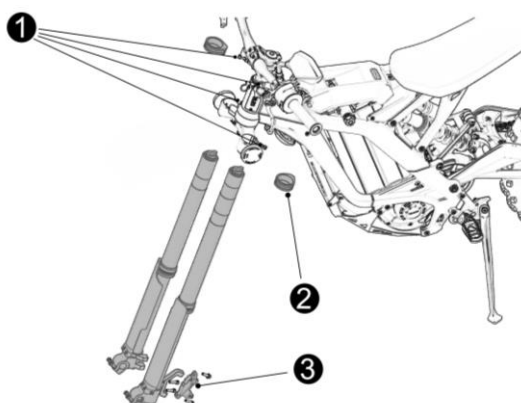

Fig 15

6.5 Dismount rear shock absorber and cocket centring (see Fig 16, 17)

Dismount rear shock absorber according to the following steps:

- Put LIGHT BEE on platform or support platwise at bottom bracket area
- Unscrew the bolts of connector at the upper part of shock absorber② fix rear wheel and dismount bolts. Put the bicycle on floor.
- Unscrew the bolts of connector at the lower part of shock absorber②
- dismount shock absorber②
- Dismount bolts of cocket centring and take down connecting rod④of cocket centring⑤ and cocket centring.

6.5.1 Assembly

- Assemble rear shock absorber and cocket centring according to the inverse disassembly steps. Fasten M8 bolt of shock absorber with the torque force of 25-30N.m.



Don't damage the paint on cocket centring and bicycle frame in disassembly and assembly of shock absorber.

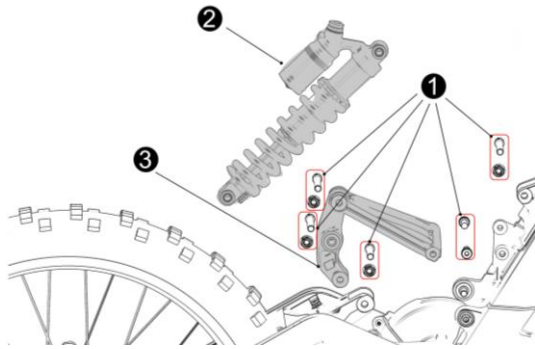
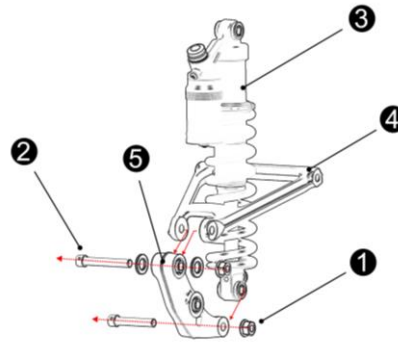

Fig 16



17Fig 17

6.6 Disassemble damping spring

Disassemble damping spring according to the following steps:

- Dismount shock absorber (see "dismount rear shock absorber")
- Unscrew preloaded adjustment nut to loosen spring.
- Dismount gasket of spring seat
- Dismount spring

6.6.1 Assembly

- Assemble damping spring according to the inverse disassembly steps.

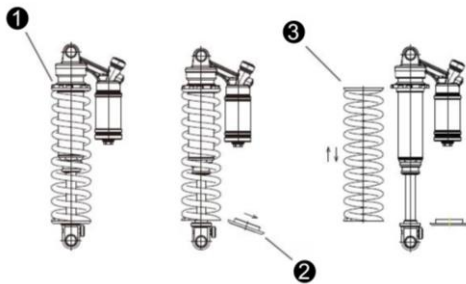

Fig 18

7. Check, disassemble and assemble head parts

7.1 Check the stroke gap of head parts

Fig 15

If head parts have gap or steering position has resistance, check the tightness of bolt ① of cover of head parts. The correct torque is 8-10N.m. Before adjusting the bolt, fasten the two fastening bolts between handlebar and stand pipe and the fastening bolts on connecting plate.

- If necessary, fasten or unscrew bolts. If the recommended torque can't be achieved by fastening, starlike nuts may be damaged. In the case, you must use new head parts.
- If head parts can't work normally (resistance in steering, gap or overhigh resistance) after the recommended torque is achieved by tightening, some parts on bearing may be damaged. In the case, you must use new head parts.

7.2 Disassemble head parts

Disassemble the head parts of Light Bee according to the following steps:

- Put Light Bee on support at bracket area
- Dismount front bow cap and instrument (see "disassemble front bow cap and instrument"). Don't damage instrument line.
- Dismount front fender and front wheel (see "dismount front wheel assembly")
- Dismount brake handle (see "separate brake handle from handlebar")
- Unscrew locking bolts between handlebar and stand pipe of steering column (see Fig 16).
- Unscrew locking bolts of upper and lower connecting plate of front shock absorber
- Dismount lower connecting plate and shock absorber assembly and ensure no falling parts
- Dismount bearing cover of head parts
- Dismount starlike nuts. Install nuts inside stand pipe of steering column through pressure. Use M6 thread rod to push nuts out from above.



If any part is damaged when drawing out head parts, install new head parts to ensure the normal operation of system.

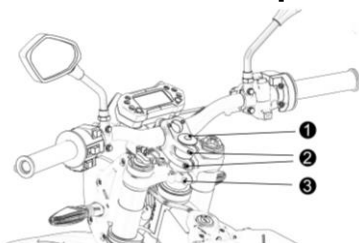

Fig 19

7.2.1 Assembly

- Assemble head parts according to the inverse disassembly steps and with the following torque values:



Important matters: fasten cover of head parts, upper connecting plate and clamp bolts between handlebar and steering column and locking bolt of shock absorber of upper connecting plate successively.

- Fasten upper connecting plate and M5 bolt between handlebar and stand pipe of steering column with the torque of 8N.m.

Locking M16 bolt of front shock absorber: 10-12N.m

Use special tool to pass new starlike nuts through the upper hole of stand pipe of steering column.



Be careful when inserting starlike nuts. If it is at a deeper position than the designed depth, locking bolts are not long enough to achieve proper fastening.

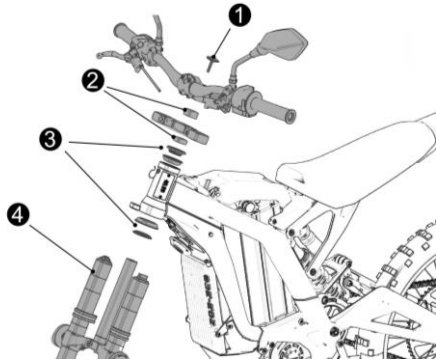

Fig 20

8 Disassemble and assemble shifter assembly (Fig 21)

Disassemble head parts of Light Bee according to the following steps:

- Put Light Bee on support at bracket area
- Dismount left and right rearview mirror
- Dismount handle grips, fuser and switch. Don't damage switch line.
- Dismount upper pump of brake (see "dismount upper pump from handle bar")
- Dismount locking bolts between handlebar and handlegear tube (see Fig 16), take handle gear down

8.1.1 Assembly

- Assemble shifter assembly with the following torque and according to the inverse disassembly steps:
- Fasten main pump of disk brake and M5 bolts between handlebar and handlebar tube with the torque of 8-19N.m.

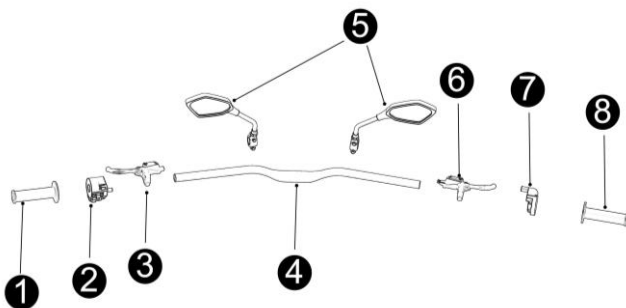

Fig 21

9. Check wheel

9.1 Check tire

9.1.1 Tire status

The height of sliding block of tire must be checked regularly. The acceptable minimum height is 2mm. If its height is lower than 2mm, replace tire.

9.1.2 Pressure

Tire pressure examination is aimed at cooled tires, so tires should not be used within a few hours before examination. The recommended pressure for front and rear wheels is 225KPa.

Inappropriate pressure or tire may cause:

- unexpected cracking
- lose control of bicycle
- low pressure causes increased rolling resistance
- premature wear
- clamping and piercing

9.2 Check wheel rim

Deformation examination for wheel rim should be conducted according to the following steps:

- Put Light Bee on support at bracket area
- Confirm wheels rotate automatically. Check whether wheels swing transversely (see Fig 22). If they swing transversely, measure their transverse motion through indicator. If transverse motion exceeds 1.5mm, check whether wheel rim is deformed or bearing is damaged. If wheel rim is in a good condition, check whether tire is installed on wheel rim correctly.

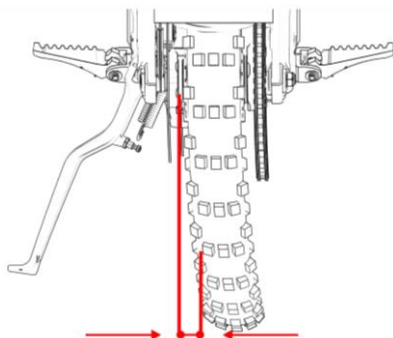

Fig 22

If wheel rim is normal and it is vertical (see Fig 23), bottom fork may be bended or incorrect. Check bottom fork.

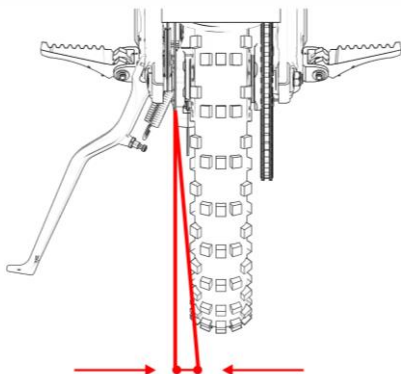

Fig 23

9.2.1 Tension of arm of wheel

Ensure the tension of arm of wheel is normal. Otherwise, bicycle may become unstable. Check whether arm of wheel is tense. If any arm of wheel is not tense, fasten it and check status of wheel rim and gap of wheel hub

10. Checking and maintenance of brake system

10.1 Check brake

10.1.1 Power examination

Before use, check whether the power and feeling of brake are normal. Force bearing point is necessary. If there is no force bearing point two thirds of stroke of brake handle, press brake rod repeatedly until it reaches brake disk.

Adjust the contact area of brake handle according to the indications in the following figure. If force bearing point is not found at the starting point of stroke of brake handle, deflate brake system (see "deflate brake")

10.1.2 Check the status of flexible brake pipe

Check the length of all flexible brake pipes and accessories with brake handle and callipers to find any potential damage or fluid leakage.

10.1.3 Check brake pad

As shown in Fig 24, the thickness of brake pad is 2.5mm at least(including metal support). Replace the brake pads of less than 2.5mm immediately.

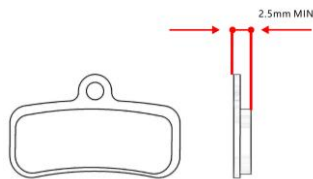

Fig 24

10.1.4 Check the thickness of brake disk

As shown in Fig 25, the thickness of brake disk is 1.6mm. Replace the brake disks of less than 1.6mm immediately.

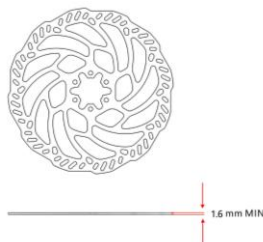

Fig 25

10.1.5 Check brake disk

Brake disk must be kept horizontal in order to ensure its normal work. Bended brake disk will make braking feeling irregular, worsen power and control of brake and accelerate the wear of brake pad.

Put LIGHT BEE on central support. Rotate wheel and observe disk passing by pad to check whether disk has indentation or is bended. If disk doesn't have friction with neighboring parts, slight transverse motion is acceptable. If disk has friction with pad at any point, replace it.



Don't touch the surface of disk or pad with hands given the grease on your fingers may lower braking force.



Prevent oil or braking oil from touching disk or brake pad. If the situation happen, replace brake pad, dismount disk and clean them with isopropyl alcohol.

10.2 Maintenance

10.2.1 Deflate brake

Deflate the brake on LIGHT BEE according to the following steps:

- Arrange necessary tools for deflation:
 - short needle cylinder for pump
 - long needle cylinder for brake caliper
 - **original brake mineral oil**



Only original brake mineral oil is allowed in deflation. DOT brake fluid is banned in any condition.

- Switch the stroke adjustment device on brake handle to (+) position.(rotate adjustment device clockwise on right brake and rotate adjustment device anticlockwise on left brake at the same time)
- Dismount brake caliper from brake (see "dismount brake caliper"). Ensure that brake caliper can be at a position lower than other line.
- Dismount brake shoe (see "replace brake shoe"). When it is used to fix the shock insulator of brake pad, fix piston on brake caliper in case that brake caliper bounces after pressing brake handle. Use rubber band to fix shock insulator.
- Fix brake caliper above brake pump (brake handle).

When there is on oil in long needle cylinder, lift brake caliper above brake pump and remove long needle cylinder from adapter.

- Dismount head bolts of brake caliper. Then, use long needle cylinder containing mineral oil into brake caliper and fasten it with a 8mm wrench.
- Fix brake handle at the angle of 45°
- Dismount bleed screw and prevent oil leakage. Remarks: the bolts are made of plastics. Be careful in operation in case of damages. Press short needle cylinder into the position of plastic bolts.
- Given the low position of brake caliper, the oil pumped from long needle cylinder flew out from the top of short needle cylinder.
- When all oil in long needle cylinder is pumped out, use long needle cylinder to pump the oil in oil line back. Repeat the process until here is no bubbles at the top (th position of brake pump).
- When there is no oil in long needle cylinder, lift brake caliper from brake pump and take long needle cylinder out with adapter.

- Put it down slowly. When oil flows out from the hole of brake caliper, put deflation plug back.
- Dampen brake caliper.
- Take needle cylinder down from brake pump carefully and place plastic bolts at the corresponding positions. (maximum torque 40Nm, prevent damages).
- Dismount gasket of piston from brake caliper.
- Reinstall brake shoe.
- Reinstall brake caliper on support of disk brake aligning to disk.
- Check whether system is normal.

10.2.2 Replace brake shoe (see Fig 26)

Dismount brake pad according to the following steps:

- Dismount brake caliper (see "dismount brake caliper")
- Dismount pin bolts ①
- Dismount brake pad ②
- Push it out through piston

, : 2.5 N.m. , . Install new pad according to the inverse disassembly steps. The torque tightening of safety bolt is 2.5N.m. After installing brake shoe, press brake handle repeatedly until the contact point between brake shoe and disk becomes stable.



After replacing brake shoe, deflate brake caliper to obtain the maximum braking force if necessary.

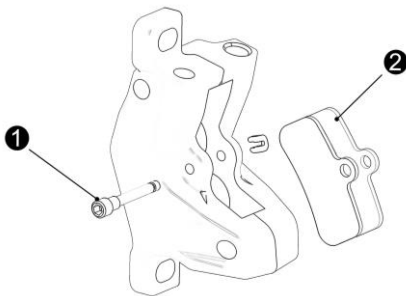

Fig 26

10.3 Dismount brake handle(see Fig 27)

Install brake handle on pump by pressing pull rod. Dismount brake handle according to the following steps:

- Fix pump firmly, press handle, dismount positioning bolts and screens gasket from pin axle. Push rod (A) down with the cylindrical tool with the diameter of less than that of pull rod. Given pull rod may be pulled out soon, be careful in operation.
- Dismount handle.

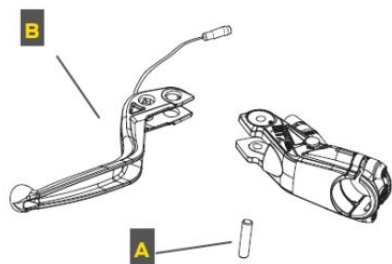

Fig 27

10.3.1 Assembly

- Assemble brake handle according to the inverse disassembly steps. Press handle to its original position with nylon hammer. Ensure spring is at a correct position.

10.4 Separate main pump of brake from handlebar (see Fig 28)

Separate main pump of brake according to the following steps:

- Dismount card holder bolts (A).
- Dismount cover of card holder (B).
- Dismount main pump of brake (C).

10.4.1 Assembly

Assemble main pump of brake according to the reverse disassembly steps. Fix fastening bolts with the torque of 4Nm. Card holder must be put at a correct position (arrows inside).

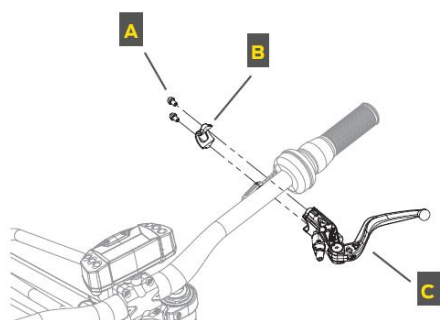

Fig 28

10.5 Dismount brake caliper (Fig 29)

Dismount brake caliper according to the following steps:

- Dismount bolts ①
- Dismount brake caliper ②

10.5.1 Assembly

- Put LIGHT BEE on support at bracket area.
- Put brake caliper ② at a correct position and fasten bolts. Don't tighten bolts for future adjustment of position of brake caliper. Use thread lock glue (Loctite 243) on bolts.
- Pinch brake handle slightly and rotate wheel. Target brake caliper at brake disk correctly.
- Keep brake pressure handle still and fasten the bolts on brake caliper with the torque force of 8-10Nm.

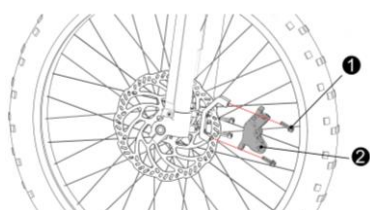

Fig 29

10.6 Dismount adapter of brake caliper (only suitable for front brake caliper)(see Fig 30)

Dismount adapter of brake caliper according to the following steps:

- Dismount brake caliper(see "dismount brake caliper")
- Dismount the bolts used to fix adapter①
- Dismount adapter of brake caliper②

10.6.1 Assembly

- Assemble adapter of brake caliper according to the inverse disassembly steps. Use thread lock glue(Loctite 243) on bolts and fasten bolts with the torque force of 8-10N.m.

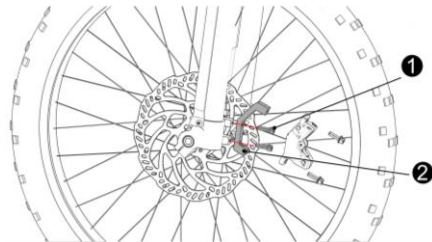

Fig 30



Important matters: check the assembly procedures of brake caliper (see "dismount brake caliper") to ensure that brake caliper aligns to disk.

10.7 Dismount front brake assembly

Dismount front brake assembly from LIGHT BEE according to the following steps:

- Dismount main pump of brake from handlebar (see "dismount main pump of brake from handlebar")
- Dismount front brake caliper (see "dismount brake caliper")
- Dismount tube clamps of flexible brake pipe and assembly.
- Assemble brake system according to the inverse disassembly steps and deflate hydraulic system(see "deflate brake caliper").

10.8 Dismount rear brake assembly

Dismount rear brake assembly from LIGHT BEE according to the following steps:

- Dismount rear main pump of brake from handlebar (see "dismount main pump of brake from handlebar")
- Uncrew rear flexible brake pipe from main pump of brake.
- Dismount flexible brake pipe
- Dismount tube clamps of internal flexible brake pipe
- Pull flexible brake pipe off bicycle frame completely.
- Dismount rear brake caliper (see "dismount brake caliper")



Remarks: a few drops of brake fluid may flow out of flexible brake pipe in the operation. The brake fluid in LIGHT BEE is mineral oil and nor corrosive. Brake fluid can be wiped with duster cloth.



Permanent damages may be caused if brake pad contacts machine oil.

10.8.1 Assembly

- Put flexible brake pipe near brake caliper on bicycle frame
- Install tube clamps
- Place parts according to the following sequence: rubber guard plate, nut, insertion piece and lubricating oil.
- Tighten flexible brake pipe and main pump of brake and ensure flexible brake pipe is not deformed. If flexible brake pipe is distortional, unscrew and correct it.
- Install rear brake caliper
- Install rear brake caliper
- Add brake fluid to line (see "deflate brake")



Remarks: in the operation, tightening brake caliper and tightness of flexible brake pipe and main pump of brake are very key and refueling and deflation are important equably. Please employ professionals for the operation and be careful.

11 Disassemble and assemble bicycle

11.1 Dismount middle bushing (see Fig 31)

Dismount middle bushing from LIGHT BEE according to the following steps:

- Dismount rear wheel from bicycle (see "dismount rear wheel") and put it on worktable.
- Dismount rear fork from bicycle (see "dismount rear fork") and put it bushing on worktable.
- Dismount lining^①of middle bushing, dismount belt wheel and chain wheel with wrench and fasten bolts^②
- Dismount belt wheel and small chain wheel^③
- Take oil seal of bushing down with special tool^④
- Take bearing and internal lining of middle bushing down with special tools

11.1.1 Assembly

- Assemble middle bushing according to the inverse disassembly steps, smear lubricating grease on bearing, lining and oil seal. Use thread lock glue (Loctite 243) on fastening bolts and fasten bolts with torque force of 10-12N.m.

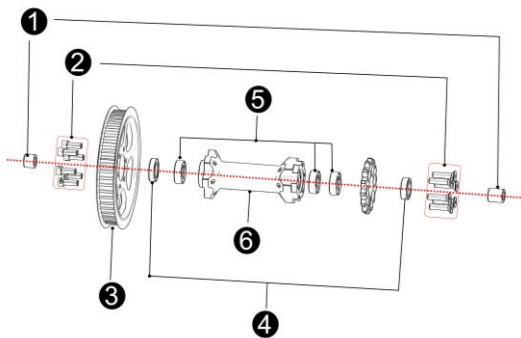

Fig 31

11.2 Dismount side cover of electrical machine (see Fig 32)

Dismount side cover of electrical machine from LIGHT BEE according to the following

steps:

- Dismount fastening bolts ① of side cover of electrical machine and put them ② on worktable.

11.2.1 Assembly

- Assemble side cover of electrical machine according to the inverse disassembly steps. Fastening torque 4-5N.m.

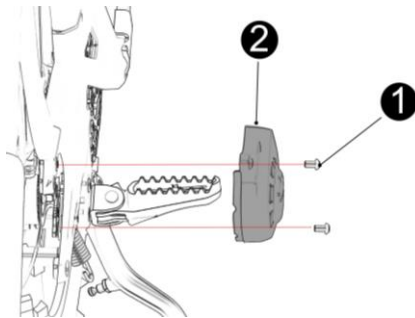

Fig 32

11.3 Disassemble side cover of electrical machine (see Fig 33)

Dismount side cover of electrical machine according to the following steps:

- Dismount combination screws of side cover of electrical machine on platform with tools and separate side and cover ①②

11.3.1 Assembly

- Assemble side cover of electrical machine according to the inverse disassembly steps.

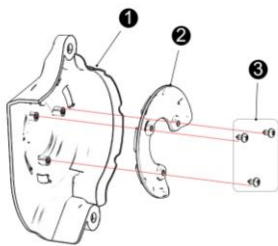

Fig 33

11.4 Disassemble and assemble first level transmission belt

Dismount first level transmission belt from LIGHT BEE according to the following steps:

- Dismount side cover of electrical machine from bicycle (see "dismount side cover of electrical machine")
- unscrew bolts on upper electrical machine of bicycle and dismount belt and increase pre-pressure (see "dismount electrical machine assembly")
- Dismount bottom fork assembly from bicycle (see "dismount rear fork assembly") and take first level transmission belt down.

11.4.1 Assembly

- Assemble first level transmission belt according to the inverse disassembly steps. Fastening torque M8: 25N.m, M10:35N.m.

11.5 Dismount left pedal assembly (see Fig 34)

Dismount left pedal assembly from LIGHT BEE according to the following steps:

- Put the cork base of bicycle down on platform with rear wheel suspended, lift side stand.
- Dismount switching line, fix belting, disconnect side stand and and cut off switching line.

Avoid damaging switching line.

- Dismount fastening bolts of left pedal assembly①and left pedal assembly②from bicycle.

11.5.1 Assembly

- Assemble left pedal assembly according to the inverse disassembly steps. Tightening torque 25-30N.m.

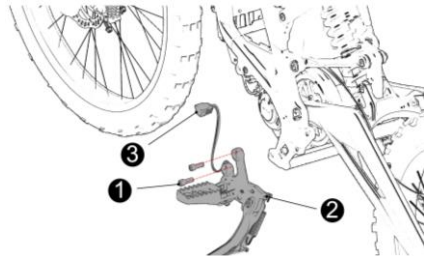

Fig 34

11.6 Disassemble left pedal assembly (see Fig 35)

Disassemble left pedal assembly according to the following steps:

- Use tools to disassemble return spring③of side stand on platform and avoid harms caused in the disassembly of spring.
- Dismount side stand, install stepped screw and separate side stand①and left pedal support②
- Dismount side stand on left pedal support, turn off sensor and use special tools to take the induced magnet on side stand down.
- Dismount hanging hook of spring of side stand on left pedal support④.

11.6.1 Assembly

- Assemble left pedal assembly according to the inverse disassembly steps. Avoid the harm caused in the assembly of spring. Smear lubricating grease on stepped screws in the assembly of side stand.

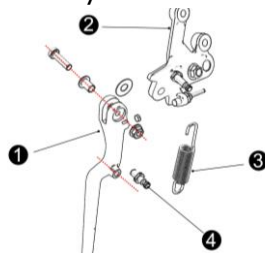

Fig 35

11.7 Dismount right pedal assembly (see Fig 36)

Dismount right pedal assembly from LIGHT BEE according to the following steps:

- Put cork base of bicycle down on platform with rear wheel suspended, lift side stand.
- Dismount fastening bolts of right pedal assembly①and right pedal assembly②from bicycle.

11.7.1 Assembly

- Assemble right pedal assembly according to the inverse disassembly steps. Tightening torque 25-30N.m.

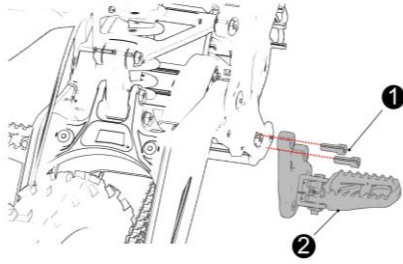

Fig 36

11.8 Disassemble pedal assembly (see Fig 37)

Disassemble pedal assembly according to the following steps:

- Use tools to dismount pedal-linked pin on platform, take return spring of pedal down and separate pedal and adapter bracket of pedal (1)(2).
- Dismount side stand, install stepped screws and separate adapter bracket of pedal (2) and pedal support (3).
- Dismount side stand on left pedal support and turn off sensor (4).
- Dismount hanging hook of spring of side stand on left pedal support (5).

11.8.1 Assembly

- Assemble pedal assembly according to the inverse disassembly steps. Tightening torque of adapter bracket of pedal 40-45N.m.

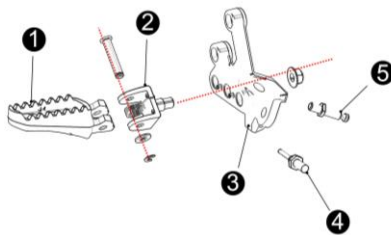

Fig 37

11.9 Dismount guard plate under electrical machine (see Fig 38)

Dismount guard plate under electrical machine according to the following steps:

- Put side stand down on floor to support bicycle stably.
- Dismount guard plate of electrical machine, fasten bolts and thread holder (1)(2) and take guard plate under electrical machine down (3).

11.9.1 Assembly

- Assemble guard plate under electrical machine according to the inverse disassembly steps. Tightening torque of bolts 20N.m.

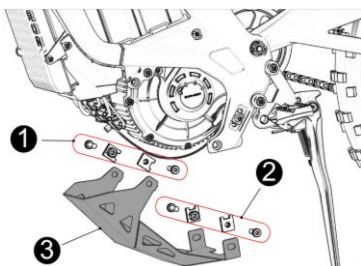

Fig 38

11.10 Dismount guard plate under controller (See Fig 39)

Dismount guard plate under controller according to the following steps:

- Dismount protective guard under electrical machine (see “dismount protective cover under electrical machine”)
- Dismount fastening bolts of protective cover under controller ①② take protective guard under controller down ③

11.10.1 Assembly

- Assemble guard plate under controller according to the inverse disassembly steps. Tightening torque of fastening bolts of M6 protective guard 5N.m

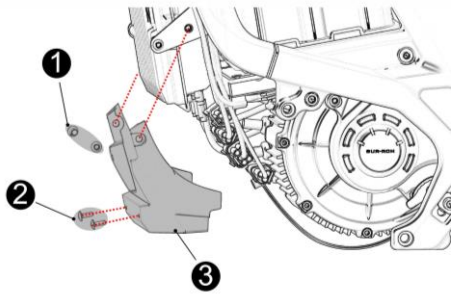

Fig 39

11.11 Dismount air switch combination (see Fig 40)

Dismount air switch combination according to the following steps:

- Dismount power battery of bicycle (see “dismount power battery”)
- Dismount control system of bicycle (see “dismount controller”)
- Dismount fastening bolts ① of support of air switch combination ③ and bolts ② respectively, disconnect and topple wiring of sensor and take air switch combination ③ down.

11.11.1 Assembly

- Assemble air switch combination according to the inverse disassembly steps. Tightening torque of M6 fastening bolts 10N.m.

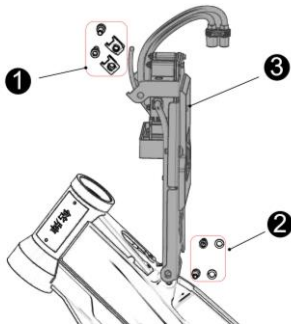

Fig 40

11.12 Disassemble air switch combination (see Fig 41)

Disassemble air switch combination according to the following steps:

- Dismount wiring of dumping sensor, install support ① and take down dumping sensor. Avoid damaging sensor line.
- Dismount air switch, fix bolts, cut belting of wiring harness, take air switch ②, nylon dividing bushing and fixing wire clamp down.
- Dismount limited block of front support of battery.
- Take front pack PE foam ④ down from support ③ through knife.

11.12.1 Assembly

- Assemble air switch combination according to the inverse disassembly steps. Tightening torque of M6 fastening bolts 10N.m. Generally, pack PE foam of front buffer doesn't have to be replaced. It contains mucilage glue and can't be used repeatedly. If you need to to replace it, sticking is suggested.



Notice: dumping sensor is assembled according to the arrows on protective jacket of sensor. Arrows must be upward. Otherwise, bicycle won't start.

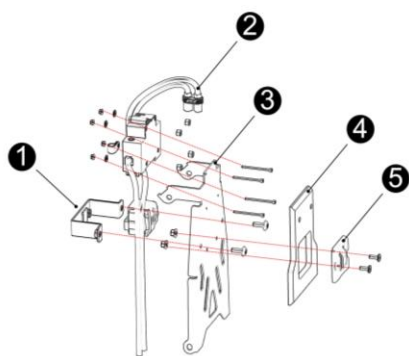

Fig 41

11.13 Dismount US and electric control lock combination (see Fig 42)

Dismount USB and electric control lock combination according to the following steps:

- Dismount USB and fastening bolts of cover of electric control lock ①
- Take USB and cover of electric control lock combination out from above. Avoid damaging electrical circuit because of large force and disconnect USB and electrical interface of electric control lock.

11.13.1 Assembly

- Assemble USE and electric control lock combination according to the inverse disassembly steps. Tightening torque of M6 fastening bolts 5N.m

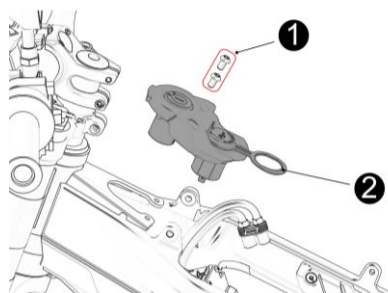

Fig 42

11.14 Disassemble USB and electric control lock (see Fig 32)

Dismount USB and electric control lock combination according to the following steps:

- Use tools to press limited mortise and tenon of electric control lock, pull it upwards and take electric control lock out ①
- Dismount fastening plastic nuts ④ of USB, take USB ② and waterproof plastic cap ③ out and separate ②③

11.14.1 Assembly

- Assemble USB and electric control lock according to the inverse disassembly steps. Avoid

damaging plastic nuts because of large force.

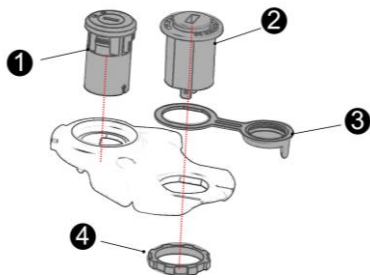

Fig 43

11.15 Disassemble electrical machine assembly (see Fig 44)

Dismount electrical machine assembly according to the following steps:

- Put LIGHT BEE on support. Reinforce rear wheel. Suspend cock base at electrical machine area or use mobile lifting tool to support it.
- Dismount guard plate under electrical machine of bicycle (see "dismount guard plate under electrical machine")
- Dismount control system of bicycle (see "dismount controller")
- Dismount side cover of electrical machine (see "dismount side cover of electrical machine")
- Use lifting tool or hands to support electrical machine⑨, dismount bolts⑤⑥ and ①⑦ successively and take lining, tensioner and gasket②③④⑧.
- Support and move electrical machine⑨, separate belt and electrical machine and take electrical machine⑨ down

11.15.1 Assembly

- Assemble electrical machine assembly according to the inverse disassembly steps. Tightening torque of fastening bolts of M8 electrical machine 25N.m.



Notice: after combining belt and electrical machine, install bolts①⑤⑥⑦ on belt and screw ① and ⑤ successively. Use tools to adjust tensioner to make belt tense until its elasticity can be felt with hands. In assembly, the height of bolts①⑤ should be kept consistent in order to make first level belt wheels parallel. Otherwise, belt may have abnormal sound.

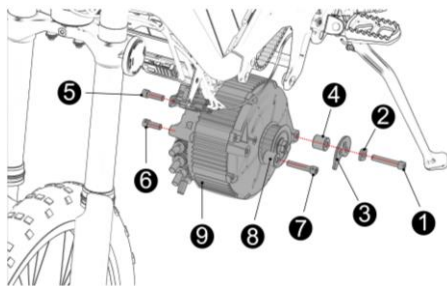

Fig 44

11.16 Dismount tailstock assembly (see Fig 45)

Dismount tail stock assembly according to the following steps:

- Put LIGHT BEE on support.
- Dismount rear and inner fender (see "dismount rear and inner fender"). disconnect

taillight and GPS interface (), avoid damaging electrical interfaces.

- Dismount power battery (see "dismount power battery")
- Dismount support^④ connecting to seat of battery lock and fastening bolts of bicycle frame^⑥
- Dismount fastening bolts of trim cover of seat of battery lock^①
- Dismount left and right fastening bolts^{②⑤} of tailstock and take tailstock assembly^③ down.

11.16.1 Assembly

- Assemble tailstock assembly according to the inverse disassembly steps. Tightening torque of bolts of M8 tailstock 20N.m, tightening torque of M6 bolts 8~10N.m.

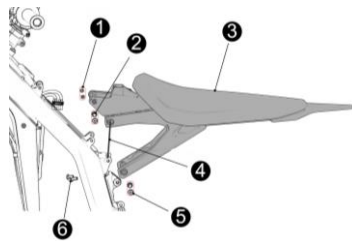

Fig 45

11.17 Disassemble tailstock assembly

Disassemble tailstock assembly according to the following steps:

- Put tailstock on platform.
- Dismount tightening bolts of trim cover of seat of battery lock and take trim cover of seat of lock battery down^③
- Dismount bolts of seat cushion and take seat cushion down^①
- Dismount rear fender^⑤ from seat cushion^①
- Dismount seat of battery lock^② and attachment bracket^① from tailstock.

11.17.1 Assembly

- Assemble tailstock assembly according to the inverse disassembly steps. Tightening torque of M6 seat cushion 8~10N.m.

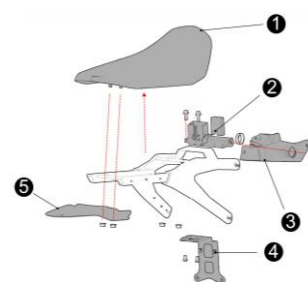

Fig 46

11.18 Dismount left and right limited blocks of battery (see Fig 47)

Dismount left and right limited blocks of battery according to the following steps:

- Dismount power battery (see "dismount battery")
- Dismount fastening bolts of left and right limited blocks of battery^① and take left and right limited blocks^② down.

11.18.1 Assembly

- Assemble left and right limited blocks of battery according to the inverse disassembly steps.

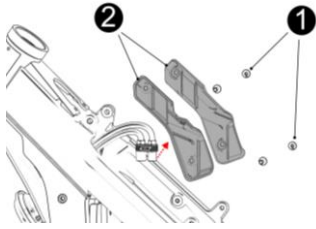

Fig 47

11.19 Dismount horn(see Fig 48)

Dismount horn according to the following steps:

- Dismount USB and electric control lock combination (see "dismount USB and electric control lock")
- Dismount fastening bolts of horn① disconnect electrical interface of horn, avoid damaging electrical interface of horn and take horn②down.

11.19.1 Assembly

- Assemble horn according to the inverse disassembly steps. Tightening torque of M6 bolts 8N.m.

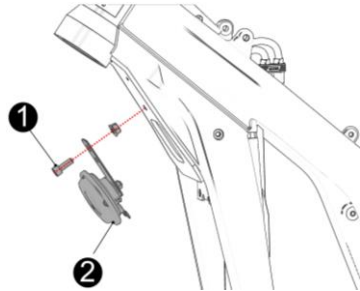

Fig 48

11.20 Dismount back shield of battery(see Fig 49)

Dismount back shield of battery according to the following steps:

- Dismount power battery (see "dismount battery")
- Dismount support connecting to seat of battery lock and fastening bolts of bicycle frame (see "dismount tailstock assembly").
- Dismount four bolts①on back shield of battery, take small guard plate②down and back shield of battery③.

11.20.1 Assembly

- Assemble back shield of battery according to the inverse disassembly steps.

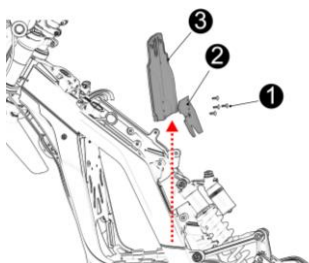

Fig 49

11.21 Dismount back wheel assembly (see Fig 30)

Disassemble back wheel assembly according to the following steps:

- Put LIGHT BEE on support at bottom bracket area

- Take belting of taillight line of rear fender down and disconnect taillight line
- Dismount fastening bolts of brake caliper of rear disk brake, take brake caliper of rear disk brake⑤ and put plastic piece with the thickness of 2mm between brake pads
- adjust adjustment bolts of rear wheel, shorten bolts to take chains down, loosen shaft of rear wheel, take lower chains③ down(if adjustment bolt of rear wheel is not short enough, use tools to dismount clip of chain interface and disconnect chain), then, take shaft of rear wheel down
- Take rear fender assembly②, back wheel assembly④ and support of rear disk brake



In the disassembly and assembly of rear wheel assembly, avoid damaging the paint on bottom fork.

11.21.1 Assembly

- Assemble back wheel assembly according to the inverse disassembly steps and use torque wrench to fasten bolts:
- Bolts of rear brake caliper: 10N.m
- Nuts of rear wheel and axle: 55-60N.m



In the assembly of rear wheel, ensure disk is between brake pads. Otherwise, brake rim or disk may be damaged.

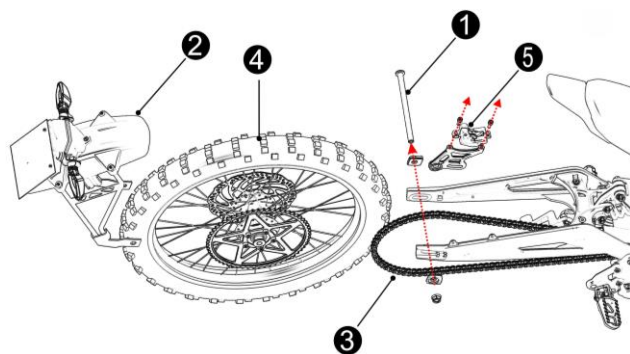

Fig 50

11.22 Disassemble rear wheel (see Fig 51)

Disassemble rear wheel according to the following steps:

- Put rear wheel assembly on worktable
- Take left and right linings①④ of rear wheel down, dismount bolts⑤ of rear brake disk, and take rear brake disk⑥ down (clean and protect disk)
- Take bolts of rear chain wheel② and rear chain wheel③ down



In the disassembly and assembly of rear wheel, don't damage the paint on wheel disk and wheel hub, clean and protect brake disk and avoid contaminating rear brake disk.

11.22.1 Assembly

- Assemble rear wheel according to the inverse dsassembly steps and fasten bolts with

torque wrench:

- Bolts of rear brake disk: 12N.m
- Bolts of chain wheel of rear wheel: 20-25N.m

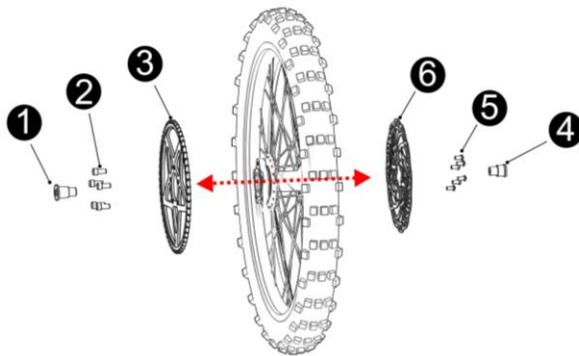

Fig 51

11.23 Dismount rear fork (see Fig 52)

Dismount rear fork according to the following steps:

- Dismount rear shock absorber, cocket centring, belt and chain of electrical machine (refer to the disassembly method of rear shock absorber, cocket centring, belt and chain of electrical machine)
- Dismount bolts of protective cover of middle bushing and take protective cover of middle bushing down
- Loosen nuts of shaft of bottom fork and take nuts of bottom fork down
- Use steering tool to push shaft of bottom fork outside and take bottom fork ① down
- Move rear fork, take down rear fork ② and middle bushing combination ③

11.23.1 Assembly

- Assemble rear fork according to the inverse disassembly steps and smear lubricating oil on bearing and bushing.

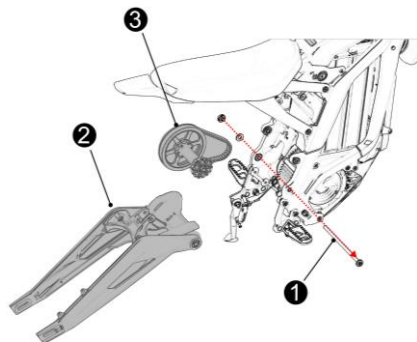

Fig 52

11.24 Disassemble rear fork (see Fig 53)

- Use tools to dismount bearing of bottom fork and take isolation pad down

11.24.1 Assembly

- Assemble bearing through pressure according to the inverse disassembly steps and smear lubricating oil on bearing and lining.

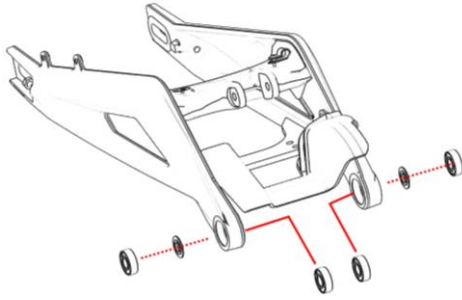

Fig 53

11.25 Disassemble rear fender assembly(see Fig 54)

Disassemble rear fender assembly according to the following steps:

- Dismount fastening bolts of cover plate of seat of taillight⑤, take cover plate, disconnect interface of taillight line, dismount belting of wiring harness and separate connecting line and rear fender.
- Dismount fastening bolts of rear fender⑥ and take rear fender assembly.
- Dismount rear fender, put it on platform, dismount fastening bolts of seat of taillight⑤ and take seat of taillight down.
- Dismount taillight②, support combination① of turn light and rear license plate④ successively.
- Dismount turn light③ and rear reflector on support① of turn light.

11.25.1 Assembly

- Assemble rear fender assembly according to the inverse disassembly steps.

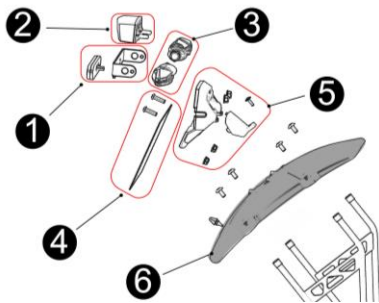

Fig 54

11.26 Disassemble rear and inner fender (see Fig 55)

Disassemble rear and inner fender according to the following steps:

- Use tools to dismount plastic screw① of rear and inner fender and take rear and inner fender down②.

11.26.1 Assembly

- Assemble rear and inner fender according to the inverse disassembly steps.

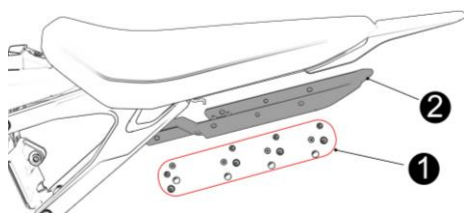

Fig 55

11.27 Disassemble and assemble cover of battery compartment (see Fig 56)

- Use keys to open cover of battery compartment. And use long flat nose pliers to take spring clip down from shaft of flat head pin①② and draw shaft of pin out①②
- Dismount cover of batter compartment

11.27.1 Assembly

- Assemble cover of battery compartment according to the inverse disassembly steps.

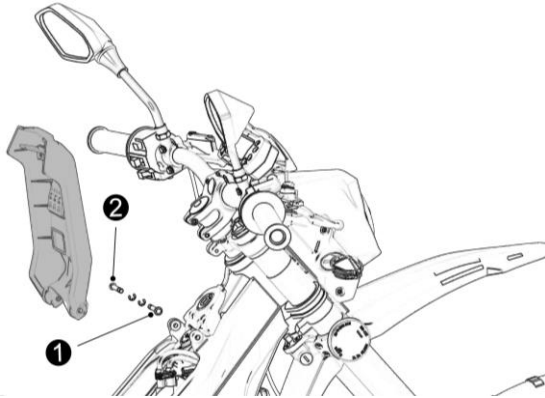

Fig 56

11.28 Dismount stop plate under battery (see Fig 57)

Dismount stop plate under battery according to the following steps:

- Dismount power battery (see "dismount battery")
- Dismount rear fender of battery (see "dismount rear fender of battery")
- Dismount electrical machine (see "dismount electrical machine assembly")
- Dismount fastening bolts①② of stop plate under battery, take speed-regulating inhaul cable down, disconnect speed-regulating center control and electrical interface of converter. Take stop plate under battery down.

11.28.1 Assembly

- Assemble stop plate under battery according to the inverse disassembly steps.

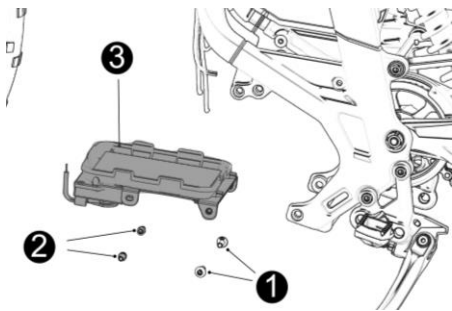

Fig 57

11.29 Disassemble stop plate under battery (see Fig 58)

Disassemble stop plate under battery according to the inverse disassembly steps:

- Use tools to take crash pad① down on platform (if any)
- Dismount fastening bolts② of stop plate③ and support④ of battery to separate ③ and ④.
- Dismount fastening bolts⑤ of power converter and speed-regulating center control and take power converter and speed-regulating center control⑥.

11.29.1 Assembly

- Assemble stop plate under battery according to the inverse disassembly steps.

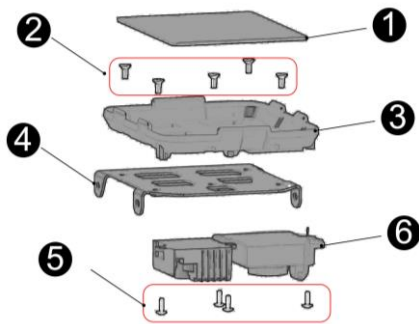

Fig 58

12. Checking and maintenance of speed regulation control device and brake control device

12.1 Check brake

If brake works normally, regular checking is very important (see "checking and maintenance of brake"). Check brake and power cut of brake. Front and rear brakes both contain a sensor. When user brakes, sensor will cut off the power source of motor. Please follow the following steps to check whether system works normally.



Warning: be careful when LIGHT BEE accelerates on worktable. It can rotate freely, so it may accelerate suddenly. Keep chain and wheel away from support or any other static parts. When bicycle is energized, don't touch wheel or drive system.

- Put LIGHT BEE on a central worktable and turn on it.
- Operate a brake, twist handle of accelerator slightly. If rear wheel accelerates, that means system has faults. Check the other brake according to the above steps.
- If system has any fault, check sensor and electrical connection of brake.

12.2 Check handle of accelerator (accelerator)

- Accelerator only can be checked on bicycle. The operation conditions and driver's operation speed and angle
- If no response is made according to the provisions, check electrical connection and perform diagnosis(refer to "electric diagnosis")

After operation, handle of accelerator must be at the position of stand-by(non power). if its is not, adjust or replace handle of accelerator.

- Check switching power supply.

12.3 Confirm power supply control

The operation on power supply control must be checked through the test on bicycle. Power output should be locked or unlocked according to the provisions.

If it doesn't work normally, check electrical connection and make a diagnosis (refer to "electrical diagnosis").

13 Position adjustment

13.1 Adjust handlebar (see Fig 59)

Ensure handlebar is fixed firmly at the center of stand pipe. If is not, unscrew the four bolts of card holder(A) of stand pipe, move it to the center and fasten M5 bolt equably. Adjust

these bolts alternatively until torque reaches 5-6 N.m.

The angle of handlebar must be adjusted in order to make users feel comfortable and safe in riding. As you change the angle of handlebar, the position of control device and brake handle will change and needs to be adjusted again. (see "adjust brake handle")

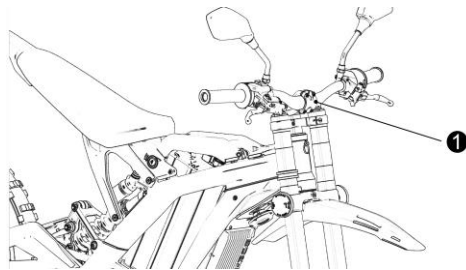

Fig 59

13.2 Adjust brake handle

Sit on the seat of bicycle and adjust brake handle with fingers. Adjust their angle to make them align to your arms when your fingers are on brake handle.

Adjust the position of brake on handlebar until users can pull the edge of brake handle with one or two fingers.

Adjust the range of brake handle with tools until users can reach handle easily with fingers.



After adjusting the position of brake rod, adjust the position of accelerator and shift lever in case of influencing brake.

14 Disassembly

14.1 Dismount handle of accelerator

Dismount handle of accelerator according to the following steps:

- dismount protective agraffe of wiring harness
- cut cable tie
- unscrew bolts of connector of accelerator
- release inhaul cable of accelerator
- Pull handle of accelerator out from handlebar

14.2 Dismount handlebar (glue)

Lift the edge of left handle and spray contract cleaner between handle and handlebar to dismount handle. Then, pull handle out.

Before dismounting right handle, cut right handle open longitudinally carefully until it can be opened and dismounted.

Before installing a new handle, clean handlebar(left) or handle of accelerator(right), smear polyurethane adhesive on its surface and plug handle into its end.

14.3 Dismount seat of fueler

Dismount seat of fueler according to the following steps:

- Unscrew the bolts of seat of fueler.
- Take fueler out from seat of fueler and release accelerator cable
- screw accelerator cable out from seat of fueler
- Pull stay wire out.

14.3.1 Install hand-held shift lever

- pass stay wire of accelerator through shell of seat of accelerator and screw shell and threaded rod of accelerator cable
- Pull core of accelerator cable out and cover handlebar with handle of accelerator.
- Connect core of stay wire to handle of accelerator. Cover handlebar with seat of fueler and fueler of accelerator.
- Rotate fueler slightly until it moves and bounces back normally and smoothly.
- Fix shell of seat of fueler A and B with bolts. When fastening bolts, adjust the angle of seat of fueler to ensure no object will influence the motion of brake handle.
- Operate fueler of accelerator to make it move normally.

15. Transmission gear

15.1 Check chain and chain wheel

15.1.1 Check chain wheel

Check the wear of front chain ring and strap. Fig 60 shows the shape of normal gear teeth and worn gear teeth. (good state/bad condition). if it is in bad condition, replace it.

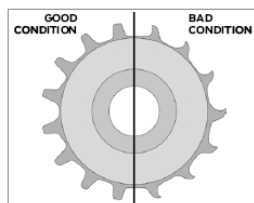

Fig 60

15.1.2 Check chain

Check the state of chain regularly. Pull chain as shown in Fig 61. If any broken tooth is found at the step, replace chain. Swing chain as shown in Fig 62 and ensure the vertical oscillating quantity of chain is 10-15mm. If the vertical oscillating quantity of chain is not 10-15mm, adjust the tension degree of chain timely. If the adjustment limit of rear wheel of bottom fork is exceeded, suggest to replace chain (see "dismount chain").

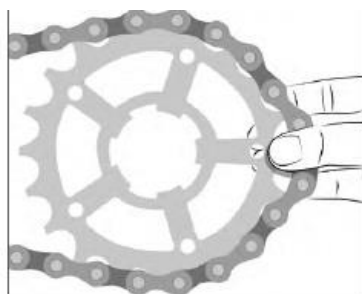

Fig 61

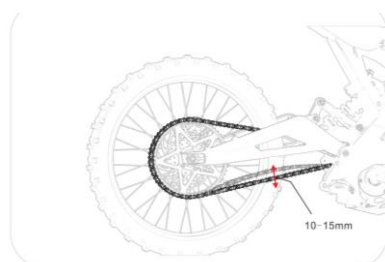

Fig 62

15.2 Clean and lubricate chain

Clean chains after use every time. It is very important to smear special chain oil to keep chains lubricated.

15.2.1 Lubrication of chain

Lubricate LIGHT BEE according to the following steps (see Fig 63):

Arrange the following objects:

- One barrel with hot water and soap.
 - One big brush.
 - One small brush.
 - Defatted cleaner.
 - chain oil of motorcycle.
 - one piece of duster cloth without traces of fabric
 - put LIGHT BEE on central worktable
 - Clean chains with big brush and plenty of soap water and wash brush frequently.
 - Clean chains of rear wheel and smear defatted cleaner on the chains of top roller below.
- Then, wipe chains with duster cloth.
- Smear a handful of chain oil of motorcycle on chains and top roller. Rotate rear wheel forwards to make all chains touch chain oil. Avoid contaminating brake system when smearing chain oil.

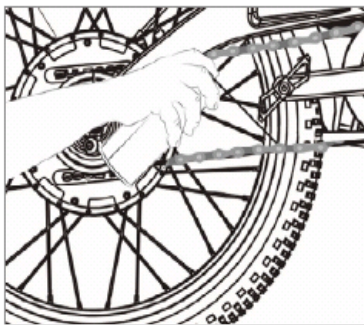

Fig 63

15.3 Dismount chains

LIGHT BEE has 420 chains, which is a fast and simple system connecting to chain links (see Fig 64).

Dismount chains from LIGHT BEE according to the following steps:

- Put LIGHT BEE on central worktable
- Adjust the position of rear wheel until minimum wheel base (rear wheel is closest to bottom fork) and maximum degree of droop and swing are obtained.
- Look for chain connector and rotate rear wheel until power chain link is below bottom fork(A)
- Push card lock-up clip① with tools as shown in the following figure. Take lock-up clip① and connecting plate② down successively. And push connector③ out from one side. You may need some long flat nose pliers in the process.



Fig 64

15.3.1 Install chains (see Fig 65)

Install chains according to the inverse dismounting steps. After chain links return their original positions, pull chains to fix chain links. Adjust chains and length of bolts. Adjust the tension degree of chains by adjusting the position of rear wheel. Ensure the vertical oscillating quantity is 10-15mm

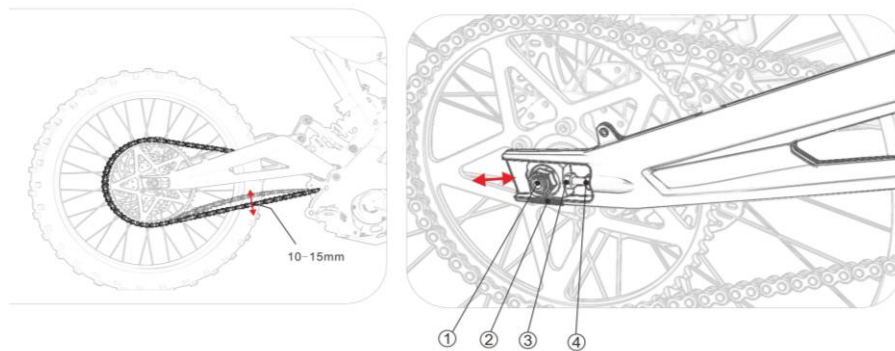

Fig 65



In installation, the opening end direction of chain lock is contrary to the movement direction of chain.

16. Electrical system

16.1 Electrical systematic drawing of bicycle

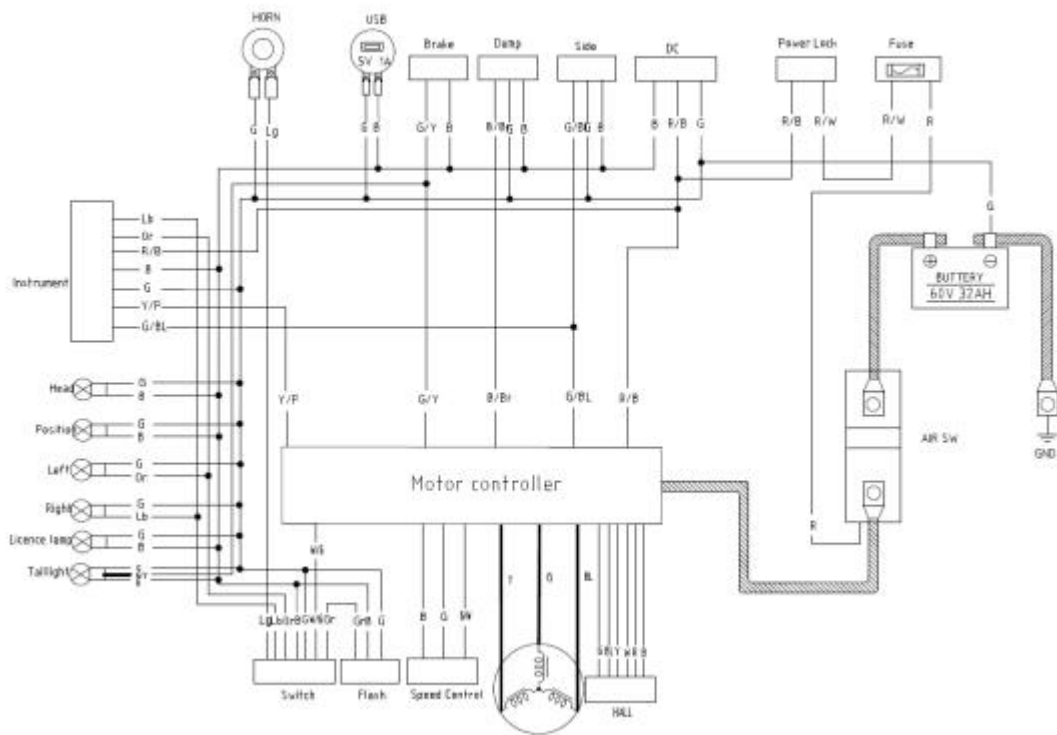

Fig 66

16.2 Check electrical system

Users must check the state of connectors of battery, controller and bicycle cable, especially the largely exposed or frequently operated parts.



Before any operation on the electrical system of LIGHT BEE, take battery out or stop other operations in case of damaging electrical elements.

17. Use and maintenance of battery

17.1. Disassembly and assembly of battery (see Fig 67)

17.1.1 Plug key ① into lock of cover of battery compartment and turn key to open cover of battery compartment ②

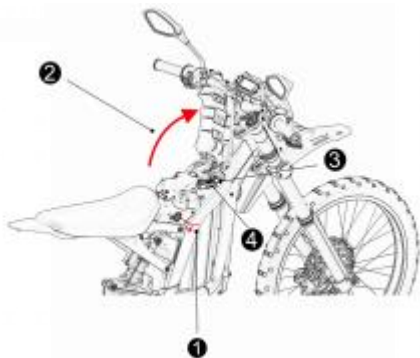

Fig 67

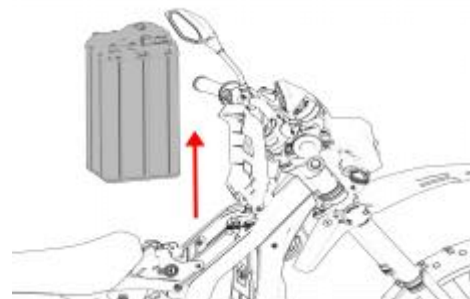

Fig 68

.Disconnect air switch, cut power source off and disconnect output power line and signal line of battery③, ④

.Hold lifting yoke of battery and lift it to take battery out (see Fig 68)

17.1.2 Assembly of battery

• Assemble battery according to the inverse disassembly steps.

17.2 Maintenance and storage of battery

Check electricity display of battery regularly. If the electric quantity of battery is lower than 20%, charge it timely. If battery won't be used for long, charge it until its electric quantity reaches about 60% and close the air switch of bicycle. Charge the battery every three months in case of inactivating battery and influencing its performance and service life.



Users can't dismount battery by themselves in case of damages and dangers. Don't throw LIGHT BEE battery in any case. If your battery needs to be replaced or discarded, send it to the designated dealers or after-sale service providers for appropriate handling.



Remember that many factors will influence the service life of battery. These factors will change greatly wit use conditions and intensity.

17.3 Charging of battery

The battery only can be charged with special lithium battery in order to avoid damaging battery or dangers.

Check whether the input voltage of charger is in line with the voltage of power grid AC110V/220V. Plug the output interface of battery into the recharge socket of battery at the left of bicycle and charge battery directly.

The silver socket at the left of lithium battery is recharge socket. Insert output plug and input plug of charger successively. (Fig 69)

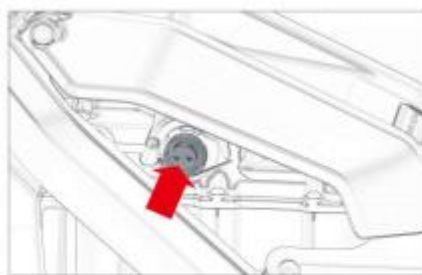

整车充电模式

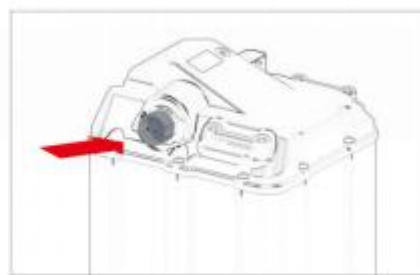

外置充电模式

Fig 69



After battery has experience discharge protection, activate it through the following ways.

Step 1: connect output end of charger to charge interface of battery and connect input

plug of charger to AC power grid. Then, the indicator of charger turns red and green alternatively;

Step 2: after "pulling-inserting" input plug of charger once, the indicator of charger turns red and green alternatively rapidly (time interval: 0.5 second) which lasts for 20 seconds;

Step 3: after 20 seconds, the red indicator of charger is on for 10 seconds. In the 10 seconds, "pull-insert" the input plug of charger once;

Step 4: at the moment, the function of "forced charging" starts, charger enters the procedures of normal charging and the red indicator of charger flickers slowly (time interval one second)

Remarks:

a、 don't "pull-insert" input plug of charger in 20 seconds in step 2. Otherwise, restart step 1 again;

b、 "pull-insert" input plug of charger in step 3 needs to be finished in 10 seconds when red indicator is on. Otherwise, restart step 1.



State of charging indicator of charger

state of indicator	red indicator flickers	green indicator is on	red indicator and green indicator flicker alternatively
state of charger	charging	finished	charging fault



About charging

Keep charging bicycle away from children.

Don't use bicycle until 10 minutes after charging is just finished.

Don't put any object on charger. The charger is used in dry and well-ventilated room.

If you smell unpleasant odor or find overtemperature in charging or indicator has not displayed fully charged for a long time, please stop charging immediately and send bicycle to repair shop.

18 Checking and maintenance of controller

18.1 Disassembly of controller (see Fig 70)

Take controller down from LIGHT BEE according to the following steps:

- Turn off and disconnect air switch.
- Disconnect battery.
- Dismount guard plate of electrical machine (see "guard plate under electrical machine")
- Dismount guard plate① under controller (see "dismount guard plate under controller")
- Dismount fastening bolts② of decorative sheet on controller and take decorative sheet and wire holder.
- Dismount fastening bolts of controller④ and fastening bolts③ successively, pull controller forwards a little violently to separate controller and bicycle. Protect wires of controller carefully.
- Disconnect electrical interface of controller and dismount fastening bolts⑤ of power source of controller and take controller⑥ of electrical machine down.

18.1.1 Assembly of controller

- Assemble controller according to the inverse disassembly steps. Tightening torque of fastening bolts of power source of controller 8-10N.m.

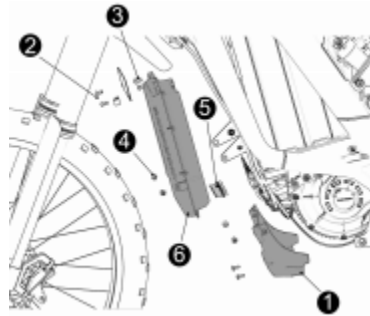

70

! Remarks: the fastening bolts of input line and output line of power source of controller must be tightened according to the required torque. Because binding post and circuit board adopt electrical welding process, excessively high tightening torque will damage binding post of controller and lead to the falling of binding post.



Warning:

- **Input line and output line of power source must be in line with the symbols on controller. Red line on positive pole of power source is connected to “+” of controller. Black line on negative pole of power source is connected to “-” of controller. The output end of controller is connected to phase line of electrical machine. “Y” end is connected to yellow line of electrical machine. “G” end is connected to green line of electrical machine. “B” end is connected to blue line of electrical machine. Otherwise, controller will be damaged or can’t start.**
- **Before the above work, disconnect air switch and power source or take battery down.**

18.2 Checking of controller

Check the wire of controller is loose and its insulation.

19、 Electrical failure checking and removal

Refer to the following table or failure diagnosis content for electrical failure checking and removal of bicycle.

fault phenom enon	possible cause	judgment method	solution
after starting, bicycle is without power	battery is not installed in bicycle or plug is not inserted into battery	check plug of battery	install battery and insert plug

air switch in front of battery has not been opened	check air switch	turn on air switch
low battery protection of battery	turn off air switch, use multimeter to check whether output voltage of discharge interface of battery is normal (DC45V-67.2V)	charge battery
battery enters low-temperature protection or high-temperature protection	check whether ambient temperature is lower than -20°C or battery temperature is too high	(-2070) wait or battery temperature becoming normal(-20°C-70°C)
protective tube of main cable is fused	check state of protective tube	replace protective tube
plug of electric door lock has bad contact	use multimeter to check whether electric door lock can be connected effectively	insert plug or replace electric door lock
converter is damaged	DC12V Use multimeter to check whether the output of multimeter is normal DC12V	replace converter
short-circuit protection of battery output	after turning on or turning off air switch, use multimeter to check whether the output voltage of charging interface of battery is normal(DC45V-67.2V). If voltage is tested when air switch is turned off and voltage isn't tested when air switch is turned on, that means output has short circuit	If bicycle is energized after dismounting positive pole line and negative pole line of controller, that means controller has short circuit. Replace controller
battery is damaged	turn off air switch, use multimeter to check the output voltage of discharge interface of multimeter is normal(DC45V-67.2V). if the above problem can't	repair or replace battery at the designated after-sale shop

		be solved by charging with charger, that means battery is damaged	
after starting, power supply is normal but electrical machine doesn't work	switch protection of side stand	lift side stand	lift side stand
	Ausschalter protection of brake	disconnect plug of switching line of brake	After confirming the position of braking point of handle, adjust the position of Ausschalter
	protection for dumping switch not returning to its original position after bicycle backs	after lifting bicycle, turn off key and turn on key	after lifting bicycle, turn off key and turn on key
	protection for accelerator not returning to its original position after starting	check free stroke of accelerator cable	adjust free stroke
	low battery protection of battery	check electric quantity of battery	charge battery
	over-temperature protection of electrical machine	whether after long-time riding with heavy loads	use bicycle after electrical machine cools
	over-temperature protection of controller	whether after long-time riding with heavy loads	use bicycle after controller cools
	switch of side stand is damaged	disconnect switch plug of side stand	disconnect switch plug of side stand or replace switch of side stand
	Ausschalter of brake is damaged	disconnect plug of switch line of brake	disconnect switch plug of brake or replace switch of brake
	dumping sensor is damaged	disconnect plug of dumping sensor	disconnect plug of dumping sensor or replace dumping sensor
speed-regulating central controller has bad contact or is damaged	0.8V-3.4Vscrew accelerator, use multimeter to check the signal output voltage of speed-regulating central controller (black and white line, green and white line)	replace speed-regulating central controller	

		changes between 0.8V and 3.4V.	
	plug of controller has bad contact	insert and pull plug and check whether terminal is normal	insert and pull signal plug of controller
	Plug of Hoare line of electrical machine has bad contact	insert and pull plug and check whether terminal is normal	insert and pull Hoare plug of electrical machine
	fault of controller or Hoare fault of electrical machine	: use multimeter to check whether the voltage of Hoare line of electrical machine is normal: 4.2V, , ;the voltage of red line and black line is 42.V. if voltage is abnormal, that signal voltage of controller has output failure	replace controller
		When rear wheel is at different positions, use multimeter to check whether the voltage of Hoare line of electrical line is normal: The voltage of yellow line, green line and blue line for black line are respectively 0V or 4.2V. if voltage is normal, that means Hoare line of electrical machine doesn't work	replace electrical machine
after starting, power supply is normal and electric quantity of battery is not displayed	plug of electricity meter is loose		repair or replace battery in the designated after-sale shop
	electricity meter is damaged		repair or replace battery at the designated after-sale shop
charger doesn't	discharge protection of	check the remaining electric quantity of battery.	refer to battery charging and activation procedures

work	battery	If electricity meter doesn't display, battery may enter protection mode owing to low electric quantity	
charger doesn't work	battery temperature is too low or too high	060when teh temperature is lower than 0°C or higher than 60°C, charging can't happen	charge it after battery temperature becomes normal
	plug of charger has bad contact	check plug of charger	insert and plug charging plug
	charger is damaged	if bicycle still can't be charged after the above possibilities are eliminated, that means charger doesn't work	replace charger
	battery is damaged	if bicycle still can't be charged after replacing battery, that means battery doesn't work	replace battery
	electric quantity of battery is too low	check electric quantity of battery	charge or replace battery
power mode is invalid or power declines	temperature of electrical machine or controller is too high	controller enters power reduction mode	wait for electrical machine or controller cools
	power mode switch is damaged	check whether power mode switch is normal with multimeter	replace handle switch
	after outage of brake, switch is adjusted inappropriately	disconnect plug of outage line of brake	, After confirming the position of braking point of handle, adjust the position of outage sensor
electrical machine has no power in jolting	jolting leads to the protection of controller	turn off key and turn on key	turn off key and turn on key
	jolting makes plug loose	insert and pull plug and check whether terminal is normal	replace plug or terminal inside plug
	USBUSB is loose	USBcheck USB	USBinsert and pull USB
USBUSB doesn't have input	USBUSB converter is damaged	USBcheck whether the voltage of input plug of USB is normal with multimeter	USBreplace USB converter

speed is not displayed correctly	/wrong setting of km/mile	reset status of km/mile	reset state of km/mile
	modification of gear train or transmission leads to changes o reduction ratio	check gear train and transmission ratio	restore original gear train and transmission ratio
the speed on instrument doesn't change	plug of instrument has bad contact	insert and pull plug and check whether terminal is normal	replace plug or terminal inside plug
	speed signal of controller doesn't have output	check whether speed output signal of controller has voltage with multimeter	replace controller
	instrument is damaged	check whether the input signal of instrument is normal with multimeter	replace instrument
after starting instrument doesn't work	wiring plug of instrument has bad contact	insert and pull plug of instrument and check whether terminal is normal	replace plug or terminal inside plug
	instrument is damaged	check whether the input line of instrument is normal with multimeter	replace instrument
after starting, rear light is not on	plug of line of lamp has bad contact	insert and pull plug and check terminal is normal	replace plug or terminal inside plug
	lamp is damaged	12V check whether the input voltage of light is 12V with multimeter	replace light
after starting, horn doesn't work	wiring plug of horn is loose	insert and pull plug and check whether terminal is normal	replace plug of input line of horn
	switch of horn doesn't work	check whether switch of horn is normal with multimeter	replace switch of left handlebar
	horn doesn't work	, 12V press switch of horn. Check whether the voltage on plug of horn is 12V with multimeter	replace horn

20 Failure diagnosis

Electrical failure diagnosis of bicycle is achieved through failure code on instrument. When battery and controller of electric system of bicycle have failure, yellow indicator on instrument is on and LCD displays the corresponding failure code, as shown in Fig 71.



Failure codes and corresponding definition of failure are shown in the following table:

failure code	definition	solution
Er-102	MOSMOS temperature sensor of battery	repair or replace battery at designated after-sale shop
Er-103	soft start failure of battery	repair or replace battery at designated after-sale shop
Er-105	preliminary over discharge protection of battery	charge battery
Er-106	MOSMOS damage of battery discharge	repair or replace battery at designated after-sale shop
Er-107	MOSMOS damage of batter discharge	repair or replace battery at designated after-sale shop
Er-114	lack of warmth protection of battery discharge	use it after battery temperature becomes normal
Er-116	over-temperature protection of battery discharge	charge battery after battery temperature becomes normal
Er-117	over-temperature alarm of battery discharge	use it after battery temperature becomes normal
Er-118	lack of warmth alarm of battery discharge	use it after battery temperature becomes normal
Er-119	preliminary over discharge alarm of battery	charge battery
Er-120	MOSMOS over-temperature alarm of battery discharge	use it after battery temperature becomes normal
Er-201	outage protection caused by over-temperature of controller	use it after controller temperature becomes normal
Er-202	power reduction caused by over-temperature of controller	use it after controller temperature becomes normal
Er-204	Hoare failure of controller	check plug of Hoare line or replace electrical

		machine
Er-205	open-phase protection of controller	check wiring of controller or replace controller
Er-206	overcurrent protection of software of controller	check wiring of controller or replace controller
Er-207	overcurrent protection of hardware of controller	check wiring of controller or replace controller
Er-208	power tube failure of controller	replace controller
Er-209	current sampling benchmark failure of controller	replace controller
Er-211	earth fault of shifter of controller	check wire of speed-regulating central controller or replace speed-regulating central controller
Er-212	protection of flywheel trip for shifter of controller	check free stroke of accelerator cable
Er-213	undervoltage protection of controller	charge battery
Er-215	outage protection caused by over-temperature of electrical machine	use it after temperature of electrical machine becomes normal
Er-216	power reduction caused by over-temperature of electrical machine	use it after temperature of electrical machine becomes normal
Er-217	485communication failure of battery 485	485check 485 communication line
Er-218	SOC low capacity of SOC of battery	charge battery
Er-219	power reduction caused by over-temperature of battery	use it after battery temperature becomes normal
Er-221	power reduction caused by battery undervoltage	charge battery
Er-222	power down failure of key	check power source of key
Er-223	power-off protection of dumping	turn off key and turn off key after lifting bicycle
Er-224	power-off protection of side stand	lift side stand or disconnect switch plug of side stand